

# Model Aircraft Design

---

A teaching series for secondary students

## Contents

Introduction

Learning Module 1 – How do planes fly?

Learning Module 2 – How do pilots control planes?

Learning Module 3 – What will my plane do?

Learning Module 4 – How big should my wing be?

Learning Module 5 – What shape should my wing be?

Learning Module 6 – What should my tail look like?

Learning Module 7 – How powerful should my motor be?

Learning Module 8 – Where should I put everything?

Further Reading

Project Suggestions

About the Author

## Introduction

This teaching series was written with the intent of applying professional aircraft design principles to simple radio controlled aircraft design at a level that is accessible to secondary students. The Learning Modules are written sequentially, but can be referenced separately. The teaching series covers a number of different design aspects. The Learning Modules are not exhaustive, and many topics have been omitted as they are too complex to tackle, or their effect is trivial in the design of simple model planes.

The Learning Modules have been written in a casual, conversational style to engage the reader and make the content more accessible to less technical readers. Teachers planning to use these Learning Modules may decide to read them themselves and adapt lessons from them, or to present them as they are to students to work through them. This is at the discretion of the teacher, as they know best the requirements of their students and what will fit within their lesson plans and curriculums.

Various advanced concepts have been added at the end of the Learning Modules. These may cover complex aircraft designs, or more mathematically advanced techniques. Aircraft design covers a large number of disciplines, from creative and artistic inspiration to precise mathematic calculation, and the advanced concepts help to cater for a wider range of educational needs.

Some students may embrace the topics presented here more than others, and may want to continue to study aircraft design. At the end of the guide a Further Reading section has been provided with links to online resources and printed texts that students can study independently. There are also a number of suggested projects a student may like to tackle, either independently or as part of their SACE Research Project. University students may be available to help mentor students in their studies, and this would give secondary students a chance to learn and research topics usually found in advanced undergraduate and masters degrees.

This guide was written to accompany the plans and build instructions for two radio controlled planes, the Valley View ACE and the Extra 300. These documents contain the information required to build and fly these planes. This teaching series was written to supplement this information and allow for expansion, but this teaching series alone is not sufficient to build a radio controlled plane, as build techniques and some specific information have not been provided. This information is readily available on the internet, and some links are provided in the Further Reading section.

## Learning Module 1

# How do planes fly?

---

It might sound obvious, but designing a plane is all about designing something that flies. If a plane doesn't fly, it's useless, and if it doesn't fly well it's not a very good plane. The first step in designing a plane that flies well is understanding what makes a plane fly. When you understand this, you can begin to understand how the changes you make to a plane will affect the way it flies.

### The Basics

Let's start by looking at a passenger jet, maybe a Boeing 737, flying from Adelaide to Melbourne. We'll ignore the take-off and landing for now and look at the main segment of the flight, called "cruise." During this time, the plane is not getting faster or slower, it's not getting higher or lower, and it's not turning left or right. The plane is flying in a straight line at a constant speed. During this time there are four main forces acting on the plane, **Weight**, **Lift**, **Drag** and **Thrust**.

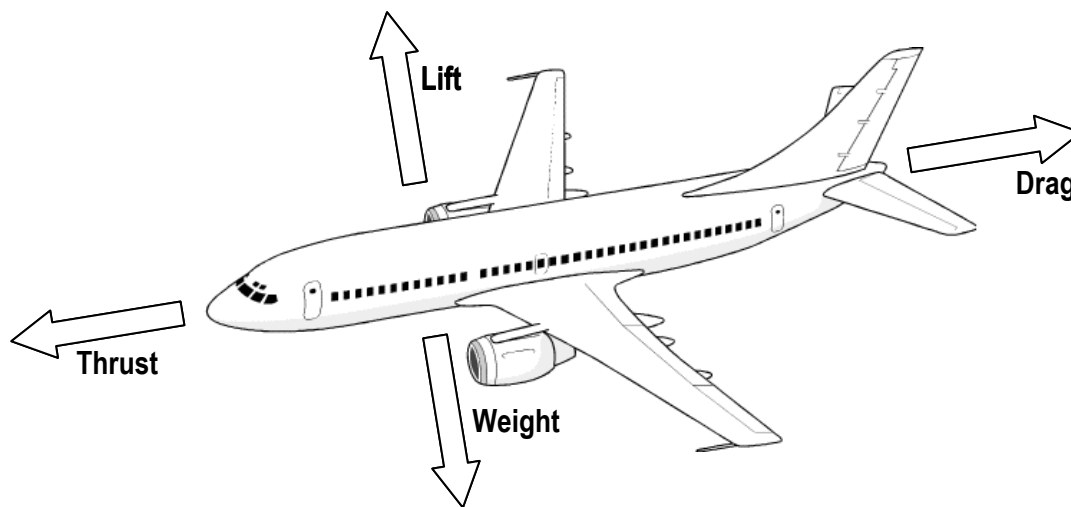

**Weight** is the force produced by gravity pulling the plane towards the ground. All objects on Earth, including humans, are pulled towards the earth by gravity. The heavier the object is, the bigger this force is. If weight was the only force acting on the plane, it would fall straight down into the Earth. In order for the plane to fly, a second force must be acting on the plane to pull it upwards. We call this force lift.

**Lift** is produced by the plane as it travels through air, mostly by the plane's wings. A plane's wings have a special shape, called an airfoil, which forces air to flow over the top surface of the wing quicker than the bottom surface. The slow moving air beneath the wing puts more pressure on the bottom of the wing than the fast moving air on top, resulting in a force that pulls the plane up and balances the weight force.

**Drag** is also produced by the plane travelling through air. When objects move through fluids, like air and water, the fluid produces a force that opposes their motion. For instance, when you push a ball floating in water it will travel in the direction you push it, but it will slow down and eventually stop. This is because the water creates a force that pushes against the motion of the ball. Air acts the same way, so to keep a plane moving forwards at a constant speed, another force is needed to overcome drag.

**Thrust** is the force produced by the plane's engines. This force pulls the plane forward through the air and overcomes the drag force produced by the air. Planes can have a variety of engines to produce thrust, but the engines usually produce thrust by turning a propeller or accelerating a stream of air. Propellers have a number of blades that rotate and create forces to pull the plane through the air. Each blade has an airfoil cross-section, like a wing, and generates a lift force. Jet engines often have fans that act like propellers, but they also accelerate a narrow stream of air. The air moves much faster than the plane, but it has a lower mass. The momentum added to the stream of air is balanced by momentum added to the plane, which provides the thrust force.

*Key idea:*

**Weight pulls a plane downwards.**

**Lift pulls a plane upwards.**

**Drag pulls a plane backwards.**

**Thrust pulls a plane forwards.**

Together, these four forces determine where the plane goes. For example, if the thrust force is greater than drag, the plane will accelerate. If the lift force is greater than weight, the plane will climb higher. It should be noted that the descriptions of the forces given here is very simplified. More detail will be added as necessary throughout later learning modules, and curious students can research this further using the resources listed in recommended reading.

## **Plane components**

Planes have a number of different components to help them fly. As we already mentioned, the wing is responsible for generating lift. The main central body of the plane is called the fuselage. This houses the cockpit, where the pilot sits. It may also contain a cabin for passengers, or a cargo bay for carrying other items. At the rear of the fuselage are the horizontal and vertical tails (or stabilisers). These help the plane to fly smoothly and stay heading in one direction. One or more engines provide thrust. These engines may turn a propeller. Engines are usually located at the front of the fuselage, or below the wings if there are a number of them, but they can also be located at the rear of the fuselage, above the wing or in the wing. Planes also have landing gear to allow them to move on the ground, and a number of controls (Aileron, Rudder etc) that will be discussed in Learning Module 2.

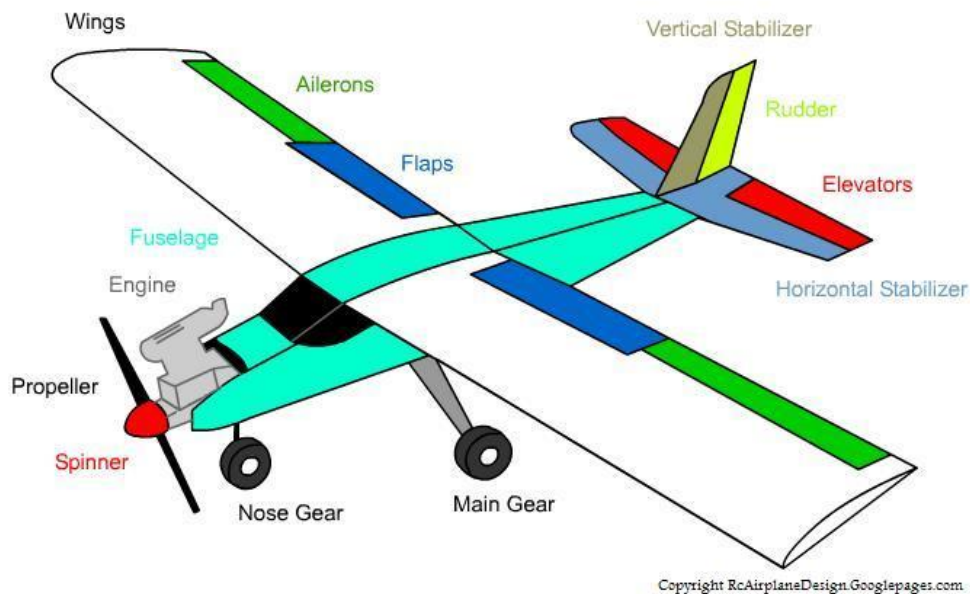

A typical plane is shown above, in this case a remote controlled model plane. Most aircraft look similar to this, because this configuration (arrangement of components) is very stable and flies well. Other aircraft have various alterations to this design, depending on what the aircraft is designed to do. Some aircraft have a lower wing, some have different tail arrangements and some have large floats to land on water. Some unusual designs also have more than one wing, and some have more than one fuselage. Most pilots learn to fly on a plane like the one shown above, however, because these planes are simple to fly, and many designers start with simple designs like this before moving on to more complex aircraft. We will discuss the different types of aircraft and what they look like in Learning Module 3.

**Images** - 737 passenger jet, <http://www.cksinfo.com/clipart/traffic/airplanes/jet.png>

- RC plane diagram, <http://theknowledgeworld.com/rc-airplane-design/Parts-of-RC-Airplane.jpg>

## Learning Module 2

# How do pilots control planes?

Now that we know which forces are acting on a plane to make it fly, we need to know how to control these forces in order to make a plane fly where we want it to. Pilots use a number of controls to do this, and some planes have different controls to others, but most planes have four main control systems: **Elevators, Ailerons, Rudder(s) and Throttle(s).**

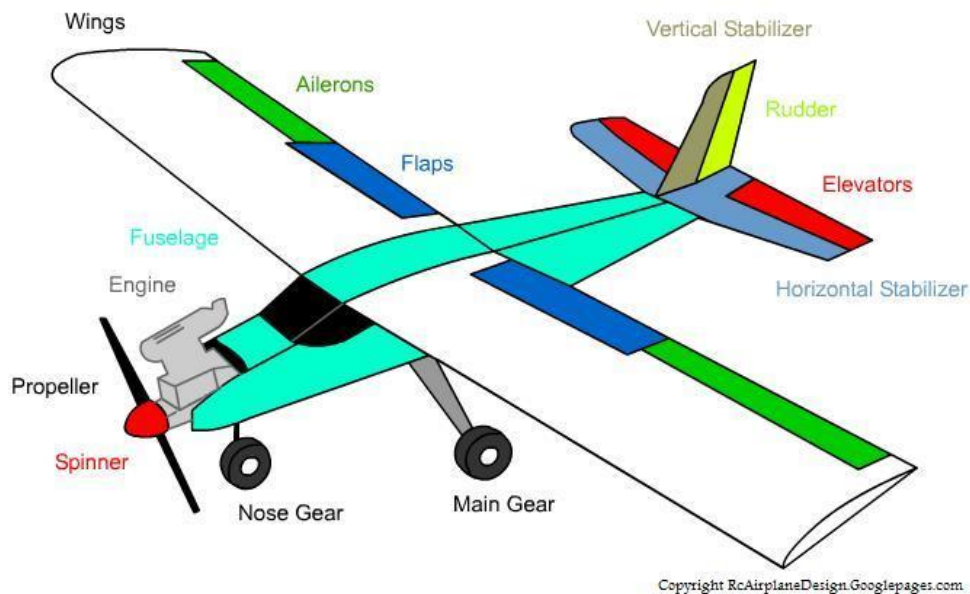

### Elevators

Elevators are located on the back of the plane's horizontal tail and are used to make the plane climb or dive. The horizontal tail, usually at the back, has a similar shape to a wing (an airfoil) and produces lift. The purpose of the tail will be explained further in Learning Module 6, but for now all we need to know is that when the tail produces more lift, the nose of the plane will go down and the plane will dive. Likewise, if the tail produces less lift, the nose of the plane will go up and the plane will climb.

Elevators change the amount of lift produced by the horizontal tail by changing the shape of the airfoil. Airfoils are usually curved like an arch, and this is one of the reasons air moves slower beneath the wings than above them. The more curved an airfoil is, the more lift it will produce. By moving the elevator at the end of a wing down, the airfoil becomes more curved and produces more lift. Likewise, by moving the elevator up, the wing is effectively less curved and produces less lift.

### Ailerons

Ailerons are located on the tips of the wings and are used to control roll. Ailerons work the same way that elevators do, by moving up and down to change the shape of the airfoil and produce more or less

lift. By moving one aileron up and the other down, one wing will generate less lift than the other. The wing that generates less lift will drop, and the one that generates more will rise, and this will cause the plane to roll.

When a plane rolls, the lift produced by the wings is no longer acting straight upwards, but is now acting upwards and towards the lower of the two wings. Because of this, the plane will now turn towards the low wing. Because of this, ailerons can be used to steer planes left or right.

### **Rudder(s)**

A rudder is located on the plane's vertical tail and is used to steer the plane left or right. Some aircraft have more than one vertical tail, like the FA-18 fighter jet, and each tail has its own rudder. The vertical tail on a plane is also an airfoil shape, but the airfoil is not curved. As a result, the vertical tail does not normally generate lift. When the rudder is moved in one direction, the vertical tail is effectively curved, and produces lift. However, this lift does not act vertically, as the vertical tail is not horizontal like the wing. Lift always acts perpendicular to the wing or tail that generates it, so the lift generated by the vertical tail will act horizontally. This lift will cause the plane to rotate left or right. If the rudder is moved to the left, it will generate lift to the right, which will move the nose of the plane to the left. Rudders are often slower at turning an aircraft than the ailerons, but they can turn the aircraft without rolling it and are useful for small adjustments during takeoff, landing and other flights. Sometimes a pilot uses both the rudder and the ailerons together while turning in order to produce a smoother flight.

### **Throttle(s)**

A throttle controls the thrust produced by an engine and is used to make the plane go faster or slower. Planes with more than one engine, like passenger jets, will have one throttle for each engine. The way that the throttle works depends on the type of engine, but it will generally increase the amount of fuel being consumed by the engine, which will in turn generate more heat or spin a propeller faster. Depending on the position of the engines, increasing the throttle may also cause the plane to climb, roll or turn. In fact, computer programs have been written that allow planes with two or more engines to be flown and landed using only the throttles! These programs are to help aircraft to land safely when the other controls have failed, and are not used very often.

*Key idea:*

**Elevators are used to make a plane climb or dive.**

**Ailerons are used to make a plane roll left or right.**

**Rudders are used to make a plane turn left or right.**

**Throttles are used to make a plane go faster or slower.**

## Pilot controls

Inside the cockpit, the pilot usually has three main controls, a **yoke**, a **throttle** and **rudder pedals**. The yoke is like a steering wheel, and rotating it will move the ailerons and rotate the plane left or right. The yoke also moves forwards and backwards, and pulling it towards the pilot will lift the elevators and cause the plane to climb while pushing it away will lower the elevators and cause the plane to dive. Modern transport aircraft and fighter jets often have a joystick instead of a yoke. Pushing the joystick forward and back has the same effect as pushing the yoke, and pushing the joystick left and right is the same as rotating the yoke. The joystick is located either centrally or to the right of the pilot.

The throttle may be a lever on the pilot's left hand side, or a knob on the instrument panel. In either case, the lever or knob is pushed forwards to increase engine thrust and pulled backwards to decrease it. Rudder pedals are located at the pilot's feet, one for each foot. The pedals are linked, so that pushing the left pedal in will move the right pedal out. By moving the left pedal forward, the rudder will move to the left, and the nose of the aircraft will turn left.

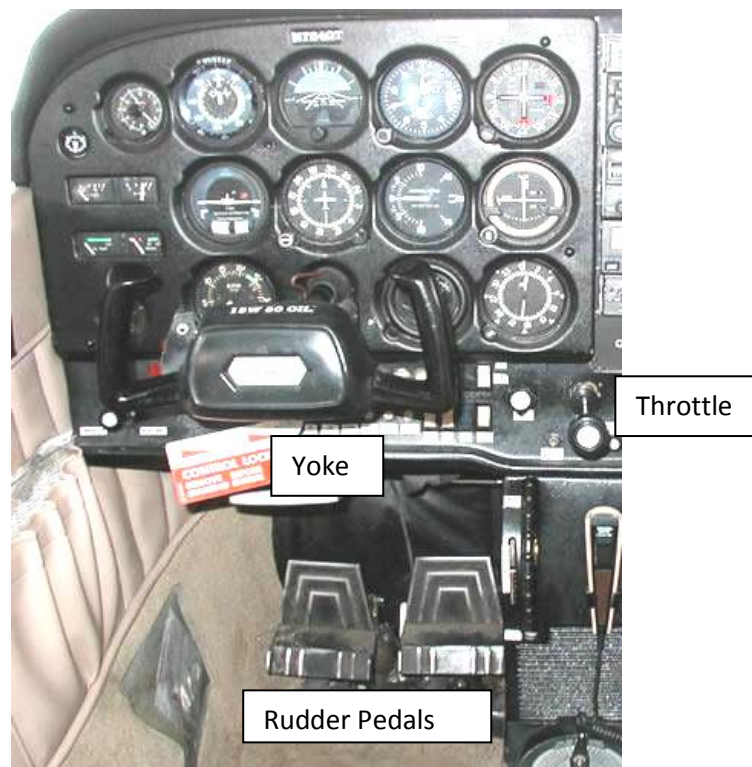

Remote control planes are controlled by radio transmitters that generally have two joysticks, one for each thumb. Depending on the design of the transmitter, the sticks will do different things. The most common system in Australia, and everywhere except America, is called Mode 1. Mode 1 controllers use the left joystick to control the elevator and the rudder, while the right joystick controls the throttle and ailerons. The right stick has springs to return it to the centre, while the left stick will only be centred horizontally. This makes it easy to find the throttle control, as this is the stick that does not centre itself vertically. Moving the left stick forward will cause the plane to dive, moving the left stick left will turn the

plane left, moving the right stick forward will cause the plane to increase speed and moving the right stick left will cause the plane to roll left.



**Images** - RC plane diagram, <http://theknowledgeworld.com/rc-airplane-design/Parts-of-RC-Airplane.jpg>

- Cessna 172 Cockpit, [http://www.aviationexplorer.com/Commercial\\_Airliners-Military\\_Aircraft\\_Pictures/cessna\\_172\\_cockpit.jpg](http://www.aviationexplorer.com/Commercial_Airliners-Military_Aircraft_Pictures/cessna_172_cockpit.jpg)

- Mode 1 Controller, [http://www.rctoy.com/pr/wp-content/uploads/2008/08/mode\\_1.jpg](http://www.rctoy.com/pr/wp-content/uploads/2008/08/mode_1.jpg)

*Advanced concept:*

## **Unusual control systems**

While most aircraft use the four control systems explained here, sometimes designers will use unusual systems in their planes. This might be because the new system is more efficient, or more practical, or the designer might want to design an aircraft that looks unusual. Here are some of the other systems that have been used in aircraft.

### **V tails**

Normal aircraft have two horizontal stabilisers and a vertical stabiliser, giving a total of 3 tails. V tails have two stabilisers that are angled like a V when viewed from behind. Each of these has a moveable surface at the back, like an elevator or rudder, and these surfaces are called ruddervators. Moving both downwards has the same effect as moving elevators down, while moving the left one down and the right one up turns the aircraft left. A complex control mixing system is needed to translate a pilot's input into ruddervator movements.

V tails were designed to reduce drag. The idea is that having only 2 tails instead of 3 would cause less drag, because each tail contributes drag. Having less drag is beneficial for an aircraft as it can fly faster or further. In practice, using only 2 tails requires you to make the tails bigger than each of the three tails would have been, and this increases drag. This means that overall there is little difference in drag. V tails can be useful for other reasons. For example, the business jet below has an engine near the tail. A normal vertical tail would be directly in the exhaust of the jet engine, which would damage the tail and reduce engine thrust, and the V tail design avoids this problem.



A V tailed business jet

(image from <http://waynefarley.com/aviation/wp-content/uploads/2010/05/vision-sf50-1.jpg>)

## Elevons

Some aircraft do not have a horizontal tail. These aircraft often have large wings that stretch along the back end of the fuselage. The aircraft do not have elevators, so elevator control is provided by the ailerons on the wing. These ailerons are then called elevons. Elevons work in a similar way to ruddervators. To roll, the elevons move in opposite directions, just like ailerons. To climb or dive, the elevons move in the same direction, just like elevators. Often, an aircraft will need to both roll and climb at the same time. A control mixing system in the aircraft will take the pilots control inputs from the yoke and work out how to move the elevons in order to make this happen.

In order for elevons to work well as elevators, they must be near the rear of the aircraft like a horizontal tail. Aircraft without horizontal stabilizers are very unstable and hard to fly. To stabilise the aircraft they either need a complex airfoil or a computerised control system, both of which are expensive to make and hard to design, but at low speeds model planes like the ACE can be flown with elevons.

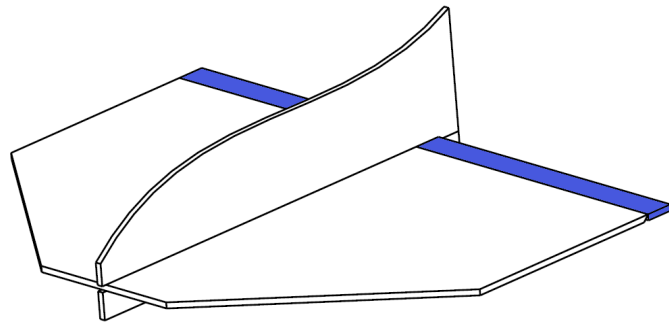

The ACE Remote control plane showing large elevons in blue.

## Learning Module 3

# What will my plane do?

---

So, you're designing your own plane? Great! What's it going to do? Well, hopefully it'll fly. That's certainly a good start. But there's a bit more to it. Do you want it to fly really fast? And perhaps it should do a whole lot of turns and tricks. And it should stay in the air forever and be able to fly all the way to New Zealand, right?

Well, if you answered yes to all of the above, we've got a problem. Some planes are really good at flying really fast and really far, but they don't turn very quickly. Other planes can fly in tight circles and do all sorts of manoeuvres (fancy word for tricks!), but compared to other planes they just crawl along! It turns out your plane probably can't do everything, and if it could you couldn't afford it! So one of the hardest parts of designing your plane is deciding what it will do, and more importantly, what it won't do.

Let's take a look at some common plane types, what they can do, and what their designs normally look like.

*Key idea:*

**One plane can't do everything!**

**Designers have to decide what their planes will and won't do**

### General Aviation – Normal Planes

General Aviation aircraft are small planes (carrying 20 people or less) that fly around between small airports. There are a few different types of general aviation planes, but the usual categories are normal, utility and acrobatic. Utility planes are for taking about 20 people a long way and we'll talk about acrobatic planes in a minute. But the biggest category of general aviation planes is the normal ones. These are the little white planes with one or two propellers that people learn to fly in. For that reason they are very stable and simple to fly. They don't usually fly too high, and they're usually slow with a short range, however some can fly faster and further than others.

Normal general aviation aircraft usually look like typical planes, with a big wing in the middle and a tail at the back, but there are some exceptions to this (Google "Vari Eze" for an example). General aviation planes with one engine normally have it at the front of their fuselage, and planes with two engines will normally have one on each wing. Often, small planes will have fixed landing gear that does not retract because it is simpler to build and less likely to fail, but this increases aircraft drag, reducing the plane's top speed (see Learning Module 1).

## **General Aviation – Acrobatic Planes**

Acrobatic planes are perhaps the most exciting type of general aviation plane. These are the planes you see flying in Red Bull air races and at air shows. Acrobatic planes are really good at performing tricks like flying sideways or upside down, turning really tightly or doing a loop. In order to do these tricks, the planes must be able to roll and climb very quickly. While they seem very fast, they're actually quite slow compared to some other aircraft, and they don't usually plan to fly very far or very high because then no one could see them!

Acrobatic planes are usually driven by a propeller at the front, and look like a normal plane with a big wing and tails at the back. The planes are usually less stable than others so that they can turn quickly (see Learning Module 8). The planes also have powerful engines so they can accelerate quickly.

## **Transport planes**

If you've ever been on a plane, chances are it was a transport plane. Transport planes are used to move people or cargo from one place to another as well as they can. There are a few types of transports designed to carry different things. Passenger planes, the ones that you and I usually fly on, are designed to move people in comfort. They're usually designed to fly quickly and cheaply, using as little fuel as they can, and they have to be very safe. Planes designed to operate in remote locations, like the Australian outback, may be designed to land on short, rough runways. Transport planes can be very large, but they often use computerised control systems that make them as easy to fly as general aviation aircraft.

Transport aircraft often have two to four engines mounted on their wings. The wings may be joined to the top or the bottom of the fuselage, depending on what the aircraft is designed to do. Transport aircraft often have a long fuselage to maximise the number of passengers or the amount of cargo they can fit on board. They need very large landing gear to land safely because all the passenger and cargo weight makes the planes very heavy.

## **Jet Fighters**

Remember how I said your plane can't do everything? Well, modern jet fighters come pretty close. They fly really fast, they can turn really sharply, they can fly really far and really high, they can carry a lot of weight and some of them can do it all without being detected! But all this comes at a price. Modern jet fighters are usually the most expensive aircraft around, and they take years to design and test.

As the name suggests, jet fighters are powered by jet engines. Many have a normal configuration (wings in the middle and a normal tail), but they may also have delta wings and tailplanes at the front called "Canards." (Canard is the French word for "duck"). Jet fighters have shorter wings than other planes to help them fly quickly. Modern jet fighters also have sharp angles on them to avoid radar detection, and they usually need to carry weapons either internally, or on racks under their wings.

## Your Plane

So now it's time to design your own plane. One of the best ways to get started is to look at other planes that you like, work out what you like about them and put all the best bits together in one plane. So perhaps you want to make a jet fighter. You might like the wing from one, and the nose and cockpit from another, and the tails of another. So you'll draw them up, move them around and change them till you're happy!

But what happens when you change things? Will it get faster? Will it turn slower? During the next few learning modules, we'll look at the results you'd expect from a few common changes, like making the wings bigger or putting in a bigger engine. But sometimes there's not enough information around to know what those changes will do, maybe because very few people have tried it! In that case, you just have to make a good guess, then go out there and try it! Then, when someone else wants to do what you did, you can tell them whether or not it works!

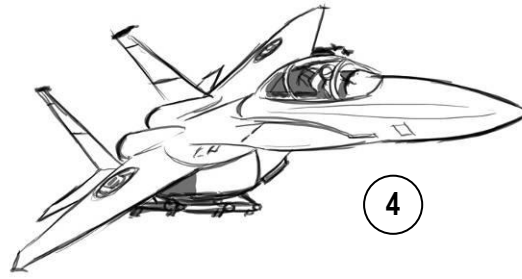
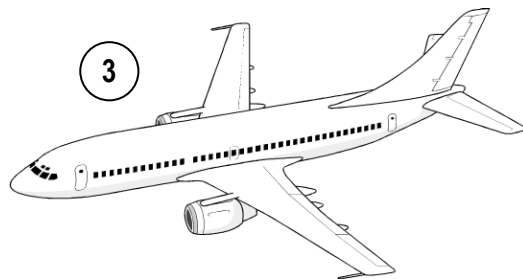
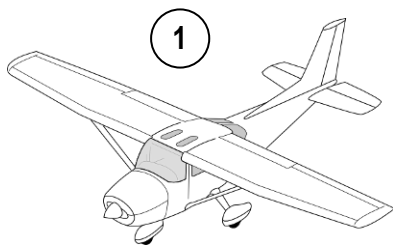

## Images

1. Normal General Aviation Aircraft  
([http://www.clker.com/cliparts/e/1/1/2/1246701343509158781C\\_172\\_line\\_drawing\\_oblique.svg](http://www.clker.com/cliparts/e/1/1/2/1246701343509158781C_172_line_drawing_oblique.svg).hi.png)
2. Acrobatic General Aviation Aircraft  
([http://upload.wikimedia.org/wikipedia/commons/f/f6/Extra\\_300S\\_-\\_Peter\\_Besenyei.jpg](http://upload.wikimedia.org/wikipedia/commons/f/f6/Extra_300S_-_Peter_Besenyei.jpg))
3. Transport Aircraft  
(<http://www.cksinfo.com/clipart/traffic/airplanes/jet.png>)
4. Jet Fighter  
([http://3.bp.blogspot.com/\\_XuJlBx1rx7Y/SIP9IjqZN7I/AAAAAAAAAso/6VZAnQBIB0g/s1600-h/OSI\\_fighter\\_plane\\_01.jpg](http://3.bp.blogspot.com/_XuJlBx1rx7Y/SIP9IjqZN7I/AAAAAAAAAso/6VZAnQBIB0g/s1600-h/OSI_fighter_plane_01.jpg))

*Advanced concept:*

## **Unusual designs**

The planes described so far in this learning module are quite typical and many have been built successfully, so they're a good place to start when designing your own plane. But sometimes normal designs aren't good enough, so here are a few unusual concepts that people have tried. Some of them never worked, and they mostly very hard to design, but they're interesting to study, and one day they might change the way we think about aircraft.

### **VTOL**

VTOL stands for Vertical Take Off and Landing. VTOL aircraft, as their name suggests, can take off and land straight up and down, without needing a runway, which makes them very useful in areas without a lot of space. The most common type of VTOL aircraft is helicopters. Helicopters are very useful, mostly because of their VTOL abilities and the fact that they can hover in one spot. However, helicopters can't fly as fast as planes, so some aircraft are designed to take off and land like a helicopter, but fly like a plane.

A lot of people have tried to build planes like this, and the most successful is called the Harrier. The Harrier has 4 nozzles through which it shoots fast jets of air. It can rotate these nozzles downwards to take off or land like a helicopter, or swivel them to face backwards and fly like a plane. One of the most advanced jet fighters in development, the F-35 Lightning II, can also hover and land vertically by rotating a nozzle at the back and using a powerful fan placed behind the cockpit. There is also a fast transport aircraft called the Osprey, which has two propellers and engines, one mounted on the end of each wing that can turn around to fly like a helicopter or a plane. VTOL aircraft can be useful, but they are much harder to design than normal planes, and often cost a lot more to build and fly.

### **Flying Wings**

The wing is one of the most important parts of a plane, generating the lift that is required to fly. It's so important that some people think it's all you really need, so they build what's called a flying wing. These planes are a big wing with some sort of engine(s) attached, and often look like a boomerang.

These aircraft often produce less drag and weigh less than other aircraft, which improves their performance. But they're very hard to design. Without a tail and a long fuselage it's difficult to make a plane stable. This means that flying wings are hard to fly, and may not be flyable at all! Using modern computerised control systems, some successful flying wings have been designed and built, like the American B-2 Spirit.

## Airborne Aircraft Carriers

You've probably heard about or seen an aircraft carrier. It's a big ship with a runway on it, and it can launch planes from any ocean around the world. This allows more flexibility than an airport, but ships are still quite slow. To counter this, people have experimented with Airborne Aircraft Carriers. These are planes or other aircraft that carry other planes up into the air and then launch them. These other planes may also return to the carrier and "land" on it, before being taken home.

The first airborne aircraft carriers were airships (like the Holden blimp you might see at sporting events). Planes were attached to metal bars beneath the airships with a hook, and would slip their hook off of the bars to launch then hook back onto these bars to "land." Later on, similar things were tried with large planes, like big transport aircraft. Smaller aircraft attached to the transport could launch and defend it if it was attacked. These aircraft were not usually very successful, and this sort of airborne aircraft carrier is not seen anymore.

Modern airborne aircraft carriers are usually used to launch aircraft that can't launch themselves from the ground. These often include experimental aircraft designed to fly very fast, or designed to fly in space. There is also a plane that was specially designed to carry the space shuttle from one place to the other. One modern airborne aircraft carrier, called White Knight Two, is designed to carry a space shuttle called SpaceShipTwo up into the sky and launch it. SpaceShipTwo is designed to take passengers for a short ride into space. White Knight Two drops SpaceShipTwo off in space, and it then uses a rocket engine to fly more than 100 km above the earth. The two planes land separately.



SpaceShipTwo separating from White Knight Two

(image from [http://www.gearlog.com/2009/05/virgin\\_galactic\\_spaceship\\_caug.php](http://www.gearlog.com/2009/05/virgin_galactic_spaceship_caug.php))

## Learning Module 4

# How big should my wing be?

---

The main purpose of a wing is to produce lift for an aircraft. Lift is the force that keeps the aircraft in the air (see Learning Module 1). Changing the size of the wing can change the amount of lift generated by the aircraft, which can affect aircraft performance.

### Size

The most important part of wing size is the area of the wing when looking at it from below. This area is called the **planform area**. The planform area, which sometimes includes the bottom of the fuselage, is an indication of the area over which lift is generated. If you have a greater planform area, there is a larger area over which lift is generated, so more lift is generated.

*Key idea:*

**Increasing planform area increases lift**

### Performance

So if we can get more lift by having a bigger wing, why don't we just have the biggest wing possible? More lift can be a good thing. It can allow the aircraft to be heavier, increasing the weight that it can carry or the distance it can fly. But the increase in lift comes at the cost of increased weight and drag.

A lot of the time, when an aircraft is flying, it will be in cruise. Cruise is where the aircraft is moving forwards without changing speed or altitude. When an aircraft is cruising, the lift force it produces must be equal to its weight. If it is lower, the aircraft will fall out of the sky. If it is higher, the aircraft will be climbing. This means that if we have more lift, we can have a heavier aircraft. This allows the aircraft to carry more passengers or cargo, meaning the person flying it can make more money. It may also increase the amount of fuel the aircraft can take, which increases its range, which is the distance that it can fly.

Larger wings also increase drag, which will increase the required power, or thrust, to move the aircraft forward. This means bigger engines and more fuel will need to be carried. Also, large wings are often longer than small wings. Long wings bend a lot more, and the wings need to be made stronger. The additional strength required means the wing will be heavier. So while the plane has more lift, it also requires more lift to carry the wings. If this is not designed well, then the extra weight of the wings may be greater than the extra lift, and the plane's cargo weight may be reduced.

*Key idea:*

**Increasing planform area can increase aircraft cargo weight**

**Increasing planform area can increase drag, and requires stronger wings**

*Advanced concept:*

### **Equation of lift**

The lift force produced by a wing,  $L$ , is

$$L = \frac{1}{2} \times \rho \times v^2 \times A \times C_L$$

where

- $\rho$  is the density of the surrounding air,
- $v$  is the true airspeed (the speed of the plane relative to the air; see Learning Module 17),
- $A$  is the planform area, and
- $C_L$  is the coefficient of lift. The coefficient of lift is a number that determines the lift produced based on the geometry, or shape, of the wing. This number changes with different angles of attack, and also with changes in speed or air conditions.

From this equation, we can see that by increasing our planform area,  $A$ , we can increase the lift force produced,  $L$ , by the same amount. We call this a proportional relation, so we say that lift force  $L$  is proportional to planform area  $A$ .

We can also see that increasing airspeed,  $v$ , will increase the lift force produced,  $L$ . The  $v$  term is squared, so whatever increase is made to  $v$ , a greater one will be made to  $L$ . For example, if airspeed  $v$  is doubled, then the aircraft will produce four times as much lift. We say that lift is proportional to the square of speed.

Lift can also be affected by air density,  $\rho$ , and the coefficient of lift,  $C_L$ . Air density is determined by altitude, and doesn't greatly affect radio controlled planes as they fly quite close to the ground (compared to passenger planes). The coefficient of lift is hard to determine and changes a lot during flight.

## Learning Module 5

# What shape should my wing be?

---

There are a lot of things you can change about the shape of a wing. Some changes are obvious, while some are more subtle, but each change affects the way that a plane flies. Since there are so many changes, and some are quite complicated, we'll focus on the simple ones that can easily be made in your designs.

### Number of Wings

Most modern planes have only one wing, but many of the first airplanes had two wings, or three, or even more! There are some advantages to having more than one wing. Biplanes are planes which have two wings, one on top of the other. Having two wings means that the wings don't have to be as wide, because the area of both wings contributes to lift. Shorter wings also allow biplanes to be more manoeuvrable, which means they can roll and turn very quickly. The wings are also stronger than a single wing, as they can support each other. The materials used to make early planes, often wood and fabric, were not as strong as modern materials like aluminium, and this made the biplane configuration very popular.

The biplane configuration has one main disadvantage. Biplanes have more drag from their two wings than a one winged plane, or monoplane. This drag only gets worse as speeds increase, and biplanes are limited to low speed flight. As time went on, people developed stronger materials, which allowed them to make monoplanes more easily. Engine technology also improved and people wanted to fly faster and faster, and biplanes fell out of favour in the 1930s-1940s.

When designing a model plane, especially a simple one made out of foam, structural considerations are less important. Monoplanes are easier to make than biplanes because they do not require braces connecting the two wings, and only one wing needs to be cut out. It is also easier to feed one wing through the body of your aircraft than two, and mounting the second wing above the fuselage would be complicated. For this reason I suggest you try a standard, one wing design.

*Key idea:*

**One wing model planes are easier to build than biplanes**

## Vertical Position

Some planes have their wing above the fuselage, and some have it below. Others have it right in the middle. The position of the wing is usually decided by what the plane is meant to do. For example, passenger jets usually have low wings under the fuselage. This means the engines can be placed under the wing and kept further from the passengers, reducing noise. Landing gear can be located on the wings and will be closer to the ground, meaning they don't have to be as long. The low wing also improves the chances of passengers surviving a crash. For example, if the plane lands in a river, it will float for a while at the level of the wing, with the passenger cabin above the water. On the other hand, a plane that's built to fly in the outback should have a high wing. This keeps wing mounted engines higher above the ground, so that they don't get damaged on bumpy, uneven runways. Planes designed to land on water also have high wings so that the wing doesn't touch the water, as this would increase drag and might damage the wing. Fighter planes often have wings in the middle of the fuselage. This helps them to manoeuvre better, as well as allowing them to see above and below the wing easily.

When building a simple model plane, the placement of the wing can be whatever the builder desires without any problems. Usually model planes are made to look like existing planes, and they simply mimic the real plane. Model planes made of foam are easiest to build with a wing somewhere in the middle of the fuselage, due to the construction method used. This allows part of the fuselage to be above the wing and part below, and the two can join around the wing for strength. The battery is often attached to the fuselage just above or below the wing. It is good to have the battery in the centre of the fuselage with regards to height or just below the centre, so a low wing with the battery on top is a good solution.

## Aspect Ratio

The aspect ratio of a wing is a measure of how long the wing is, called its span, compared to how wide it is. A long, skinny wing, like the wings on many gliders, has a high aspect ratio, while a short, fat wing has a low aspect ratio. If a wing is square, you can calculate the aspect ratio by dividing the span (measure the distance from one wingtip to the other) by the width of the wing (measure from the front edge to the back edge of the wing). Many wings are not square, often wings get narrower towards the tip and this will be discussed later. In this case, you can calculate the aspect ratio by squaring the span and dividing it by the area of the wing. We'll do an example here for the wing similar to a model Extra 300 acrobatic aircraft.

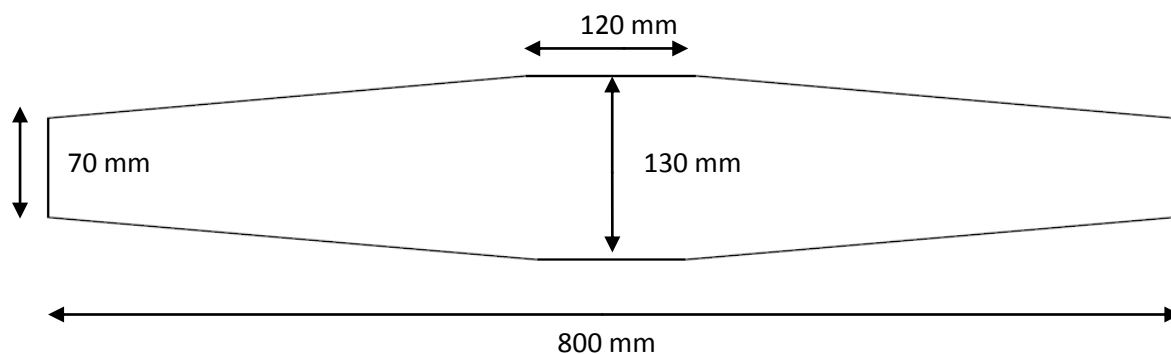

The diagram above shows the main dimensions of the wing. The span is 800 mm. To work out the area of the wing, we split it into 3 shapes, a rectangle in the middle and two identical trapezoids, one each side. The area of the square is  $120 \times 130 = 15600 \text{ mm}^2$ , and the area of both trapezoids is

$$A = \left( \frac{70 + 130}{2} \right) \times \left( \frac{800 - 120}{2} \right) \times 2$$
$$= 100 \times 340 \times 2 = 68000 \text{ mm}^2.$$

The aspect ratio is

$$\text{Aspect Ratio} = \frac{800^2}{68000 + 15600}$$
$$= 7.7.$$

This is what you would expect for a single engine, general aviation aircraft like the Extra 300. High speed fighter jets often have a lower aspect ratio wings, as shorter wings allow planes to turn faster. Transport aircraft have higher aspect ratio wings, as higher aspect ratios are more efficient, allowing the transport aircraft to use less fuel during flight, and hence fly further on the same load of fuel. Gliders have very high aspect ratios because they need to be as efficient as possible in order to fly reasonable distances and stay in the air.

An aspect ratio between about 6 and 8 should work well for model planes with normal wings. Delta wing planes like the ACE can have lower aspect ratios – the aspect ratio of the ACE is 1.8. The motor on small foam planes is strong enough that even a poorly designed wing should still fly, so feel free to experiment with your own aspect ratios.

*Key idea:*

**Aspect ratio describes how long and skinny or short and fat a wing is.**

**An aspect ratio of 6 to 8 is a good place to start for normal wings.**

## Wing Taper

Wing taper describes the way that some wings get narrower towards the tip. Taper helps to reduce drag, allowing planes to fly faster and use less fuel. The best taper to reduce this drag is an elliptical wing, like the one on the Supermarine Spitfire, a famous British fighter plane from World War 2. Elliptical wings are hard to make, so wings normally have straight edges that form trapezoids. Some low speed aircraft have rectangular wings, as these are the easiest to make. The taper is measured by the **taper ratio**. This is the width of the wing at the tip divided by the width of the wing where it intersects the fuselage, called the root. A taper ratio of 1 means the wing is the same width at both ends, so it is rectangular. A taper ratio of 0 means the wing narrows to a point at the tip, like a triangle.

A taper ratio greater than one would mean the wing gets wider, and this is rarely found in plane designs. To calculate the taper ratio of the Extra 300 wing above, divide the tip length of 70mm by the root length of 130 mm, giving a taper ratio of 0.54. The ACE also has a taper ratio of 0.54.



A Supermarine Spitfire from below, showing the elliptical wing design that minimises drag.  
(Image from [http://upload.wikimedia.org/wikipedia/commons/8/8b/Spitfire\\_mk2a\\_p7350\\_arp.jpg](http://upload.wikimedia.org/wikipedia/commons/8/8b/Spitfire_mk2a_p7350_arp.jpg))

When designing your own plane, you can use a rectangular wing if you wish as your plane will be flying fairly slowly and it should not matter too much. If you want to taper your wing, a ratio of 0.4-0.6 is a good place to start. You should also note that straight edges are easier to make. Your wing is cut out from foam, so you could make any shape you want, but a straight edge wing will be more even on both sides. Alternatively, draw one side of the wing on paper and cut it out, and use this template to make both halves of the wing.

*Key idea:*

**Tapering a wing so that it is narrower at the tips can reduce drag.**

## **Incidence Angle**

Incidence angle is the angle at which the wing is installed. Ordinarily a wing would be straight along the body of the aircraft, but sometimes the wing is angled upwards, so that the front edge is higher on the fuselage than the back edge. To understand why this would be done, we need to have another look at how airfoils work, and how much lift they produce. An important part of this is the **angle of attack**. The angle of attack is the angle between the wing and the incoming airflow. The airflow generally comes from the direction the plane is flying. If an aircraft tilts back to climb, the angle of attack increases, and if it tilts forward to dive the angle of attack decreases. The diagram below illustrates the angle of attack. Note that the chord line is a line through the wing joining the front and back edges.

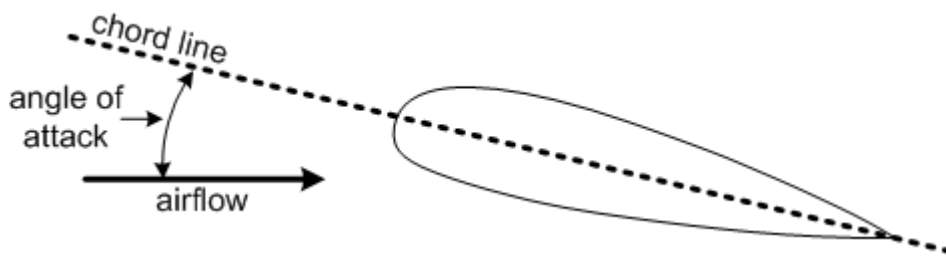

The angle of attack is the line a wing makes with the incoming airflow  
(Image from <http://www.langleyflyingschool.com/Images/Aerodynamics and Theory of Flight/Angle of Attack.gif>)

Wings produce more lift when they are at a higher angle of attack. If an airfoil is curved, then the wing will still produce some lift when the angle of attack is zero, but if it is symmetrical it will not produce any lift. This is why vertical tails usually have symmetrical airfoils, as these will not try to turn the plane when it flies in a straight line.

During cruise, an aircraft has to maintain a certain amount of lift to fly level. It may be that the airfoil chosen for the wing will only produce enough lift when the angle of attack is greater than zero, let's say 3 degrees. To do this, the whole aircraft could fly at an angle of 3 degrees, but this would mean that the pilots and passengers would have to spend most of the trip sitting at a tilted back angle. This would make it harder for meal trolleys to move up the aisle, and would also reduce the pilot's ability to see where the plane is going. The other alternative is to angle the wing at 3 degrees higher than the fuselage. This means that when the fuselage is level, the wing will be at an angle of attack of 3 degrees and will produce enough lift to fly. This angle of 3 degrees is called the **incidence angle**. Setting the wing at a positive incidence angle can also reduce the drag from the fuselage. The incidence angle is usually set by testing with wind tunnels, which is a complicated process, but in the end incidence angles are often only 1 or 2 degrees. Wings can also be twisted, where the angle of the wing changes from root to tip, but this is complicated and hard to do on model aircraft.

When making a foam model aircraft, the wing is a flat symmetrical plate. As such, the plane will need to spend most of its time flying at a positive angle. This means that it would make sense to put the wing at an angle of incidence. However, this would be much harder to make than a wing at no incidence angle. Also, there are no pilots or passengers to upset, and the extra drag does not matter too much at model aircraft speeds, so it does not matter that the aircraft will fly at some slight angle. A similar effect to an incidence angle can be gained by angling the motor downwards, and this will be discussed in Learning Module 7.

*Key idea:*

**Wings generate more lift at higher angles of attack**

**Incidence angles can make flight more convenient for passengers and reduce drag**

**Incidence angles are hard to build in model aircraft and are not necessary**

*Advanced concept:*

## Estimating the lift coefficient, $C_L$

As we saw in Learning Module 4, the lift force produced by a wing,  $L$ , is

$$L = \frac{1}{2} \times \rho \times v^2 \times A \times C_L$$

During cruise, the lift force is equal to the weight of the aircraft. If we know the weight of the aircraft, and can measure or estimate the rest of the variables, we can calculate the lift coefficient during cruise. We've already seen how to find the planform area,  $A$ , but we need to make sure we convert it into square metres. If it is measured in square millimetres, we need to divide it by 1000000.

The density of the air can be measured, but it is easier to use a standard value. The standard atmosphere is a list of air pressures, temperatures and densities at different altitudes (or heights) throughout the Earth atmosphere. Since our planes fly quite low, we'll use the sea level value of density, which is  $1.225 \text{ kg/m}^3$ . This will be accurate on days that are about  $15^\circ\text{C}$ .

The weight is simple to measure using scales, but it must be used in Newtons, a unit of force, not kilograms or grams. To convert kilograms into Newtons, multiply the weight in kilograms by 9.81. To measure the speed, find two objects that are a reasonable distance apart, like two trees near an oval. Measure or guess the distance between them. Now fly your plane as level as possible, without speeding up or climbing, past both objects and time how long it takes. Then divide the distance (in metres) by the time taken (in seconds) and you'll get a rough idea of how fast you're flying.

Once you have all these numbers, you have to reverse the above equation to find the coefficient of lift. It should look as follows:

$$C_L = \frac{2 \times L}{\rho \times v^2 \times A}$$

Let's try it with some estimates for the Extra 300 model we mentioned before. The area of the wing, in square metres, is  $0.0836 \text{ m}^2$ . Let's guess that it weighs about 350 grams, which equals 3.4 Newtons, and that it flies at about 10 m/s. Finally, using our estimate of  $1.225 \text{ kg/m}^3$  for density, we get a value of  $C_L = 0.66$

Because the wing is a flat plate, we can use something called thin airfoil theory to work out what angle it might be flying at. Thin airfoil theory tells us that the coefficient of lift for a thin flat airfoil, like a flat plate, can be estimated as

$$C_L = 2\pi \times \alpha,$$

where  $\alpha$  is the angle of attack of the wing, measured in radians. Because the wing is at the same angle as the fuselage, the angle of attack is the same as the angle that the plane is flying at.

If we divide our calculated  $C_L$  of 0.66 by  $2\pi$ , we find an angle of attack of about 0.1 radians. When converted to degrees, which is done by multiplying by 180 and dividing by  $\pi$ , this is roughly 6 degrees.

Our method used a number of estimates, so it may or may not be very accurate, but the result looks possible. Try this with your plane once it's built and see if you get similar results. If your plane is flying fairly flat, but the results say your angle of attack is quite large, there's probably a mistake in the calculations or the estimates are wrong. Anything larger than 15-20 degrees is questionable, as wings usually don't work well at angles this high. The faster you're flying, the lower the angle should be.

## Learning Module 6

# What should my tail look like?

The tail of a plane is a lot smaller than the wing, but it's just as important. Tails provide stability, allowing planes to fly smoothly and easily through the air. They also hold the elevators and rudders, which are essential for controlling where the plane flies. And finally, they have a big impact on what your plane looks like, so you want them to look cool! Here are a few hints on how to design a tail that will keep your plane stable and controllable. I'll leave the looking cool bit up to you.

### Layout

As we saw in Learning Module 2, there are a few unusual tail designs, but there's also one design that the majority of planes use. This design, usually called the conventional tail, has two horizontal stabilizers and one vertical stabilizer placed at the end of the fuselage. We're going to discuss this layout, since it's a good design and it's the one used by the Extra 300 we've mentioned before. If you're building a delta wing like the ACE, you'll be using elevons and you may not have a rudder, but you can still use this advice to plan your horizontal stabilizer. There's a diagram below with many different tail layouts. Each has advantages and disadvantages that we won't discuss here, but if you're looking to experiment you can try one at your own risk!

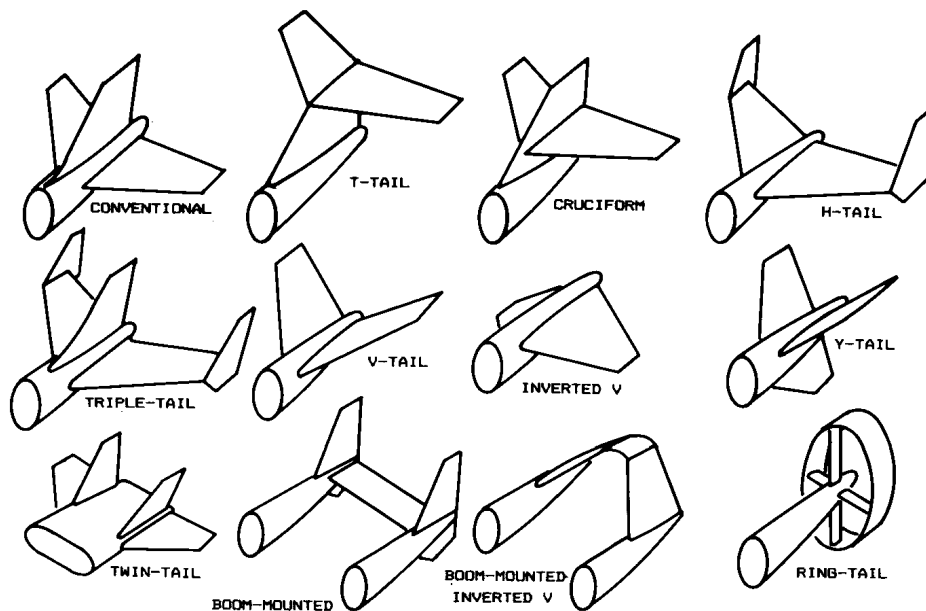

A variety of tail layouts. From "Aircraft Design: A Conceptual Approach" By Dan Raymer

## Tail Placement

All the tails shown above are placed at the back end of the aircraft. There are some alternatives, such as the delta wing without a horizontal tail that's seen in the ACE, but these can be tricky to design and fly. There are a few good reasons why tails are at the back end of the aircraft. Firstly, tails at the end of the aircraft are good for stability. This is especially true of vertical stabilizers, as putting a vertical stabilizer at the front of your plane will make it want to turn around and fly backwards! Think of a weather vane or an arrow – the fins are always on the back. Putting a horizontal stabilizer on the front of the plane, called a canard, is also unstable, but this can be balanced by the wing because the wing is also horizontal. We'll look at canards in the advanced concept later on.

Tails are usually located at the back of the plane, rather than partway through the fuselage, because tails are more effective the further back they are. The airplane has a point called the centre of gravity, which will be explained further in Learning Module 8. For now, all we need to know is that it's usually in the front half of the plane, and whenever the aircraft turns, whether it's rolling, turning or climbing, it turns around this point. If you think of your plane like a see saw, the centre of gravity is the pivot point of the seesaw, which is the fixed point in the middle that the see saw rotates around. Now, when two people play on a see saw and want to balance it, the heavier person sits closer to the pivot. This is because the further away from the pivot you get, the greater effect you'll have on the see saw.

Because tails are used to steer the whole aircraft, we want them to have the biggest effect possible. By locating them at the back of the aircraft, they will be as far away as possible from the centre of gravity. That way, when the elevator creates a lift force, it will have a large effect on the plane and it will rotate quicker. It's also worth noting that a small tail a long way back from the centre of gravity is equivalent to a large tail close to the centre of gravity, but a small tail will generate less drag. We'll discuss tail sizes later.

The last thing to note is that the location of the tails can depend on the design of your fuselage. We haven't discussed fuselage design yet – largely this will be up to you and what you think looks cool. Where you put your engine will determine a lot of your design, but you should also consider tail placement. When the engine is at the front, like most propeller planes, the fuselage gets narrower towards the back and ends in the tail. When the engine is at the back, the tail has to be located around it. Modern jet fighters often have one or two engines that point out the back, and the tail has to be located around them – the twin tail design is often used for this.

*Key idea:*

**Vertical tails must be at the back of the plane.**

**Horizontal tails can be at the front, but it's easier to put them at the back.**

**The tail should be as far from the centre of gravity as possible, which usually means the back of the plane.**

## Tail Shape

The shape of the tail is fairly similar to the wing. Aircraft tail design is a complex process, and often the shape, size and position of the tail will change a few times during the design process. There are a few guidelines to designing a tail shape that will get you started on the right track, and will be good enough for most radio controlled model planes. In the end, while some tails will work better than others, most tails will be flyable, so feel free to add your own artistic touch – this is the looking cool part I was talking about earlier.

As a general rule, horizontal tails have a lower aspect ratio than the aircraft's wing. This means they are shorter and fatter. An aspect ratio between 3 and 5 is a good place to start. The taper ratio of the horizontal tail can be similar to the wing, between 0.3 and 0.6 is a good place to start but feel free to use more or less. Draw a tail that you like the look of, then check what its aspect ratio and taper ratio are, and only change it if it's a long way outside the ranges above. Vertical tails have even lower aspect ratios, generally between 1 and 2 but they can be lower than 1, meaning the tail is longer than it is tall. It can be hard to judge the aspect ratio of a tail, especially on the ACE where the tail is curved, so just guess. As long as the tail's not a lot longer than it is wide it should be ok. Guidelines for taper ratio are the same as for the horizontal tail, between 0.3 and 0.6 is good.

The Extra 300 we mentioned earlier has a horizontal tail aspect ratio of 3.5, and a taper ratio of 0.8. The taper ratio is quite high, and the tail could be narrower, but the plane flies well and that's what matters in the end. The vertical tail has an aspect ratio of 1.5 and a taper ratio of 0.3, perfectly within the guidelines.

*Key idea:*

**Horizontal tails are usually shorter and fatter than wings.**

**Vertical tails are usually shorter and fatter than horizontal tails.**

## Tail Size

Tail size, like tail shape, is usually changed a number of times during the design of a plane. A tail that is too big causes too much drag and slows the plane down. A tail that is too small will not be able to stabilise a plane, and may not be strong enough to stop it from crashing. When designing a tail for your model aircraft, it is safer to design a tail that might be too big. If it turns out your plane is too slow, you can try to reduce the size, but if you make it too small it's hard to fix, and could cause a spectacular crash that'll be even harder to fix! Professional aircraft designers use a fancy method that compares their plane to similar planes and works out how big their tails should be. The maths involved is a little bit complicated, but the idea is really simple and easy to do yourself.

First, find a number of other planes that are similar to yours. This will depend on what sort of plane you're making (remember Learning Module 3). If you're trying to make a copy of an existing plane, that's the only one you really need to look at. Find pictures of these other planes, particularly from the side for vertical tails and above or below for horizontal tails. You may have already used these pictures to help make the wing and fuselage. Now compare the size of the tails to the wings. You can do this roughly just by looking, or you might like to measure it. Once you've designed this, draw your tail and compare it with the others. It doesn't have to be the same, but it should be similar. We'll see how to do this with an example.

Let's say I'm trying to make a passenger jet. So far I've designed the wing and the fuselage, and worked out how far back to put the tail. Now I just need to design the tail itself. We'll design the vertical tail here, but the horizontal tail design would work much the same. Below are some drawings of my plane without a tail.

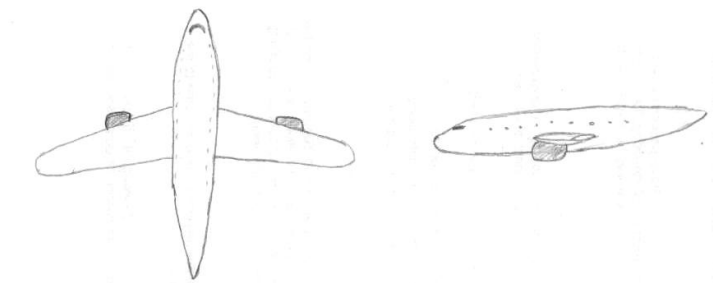

I've found a few other passenger jet pictures. Here are a Boeing 737 and an Airbus A320, from below and the side. These aircraft are a lot bigger than mine, so instead of just measuring the size of their tails, I'm going to measure the width of their wing as well and divide each tail measurement by this. This makes the measurements easier to compare. It also means I can measure straight off of pictures rather than working out the real size of the tail, as everything will still be in proportion. One word of warning, if you use separate pictures for the wing measurement and tail measurement, which you must do for the vertical tail, make sure the fuselage is the same length in both pictures. Otherwise your measurements will be inaccurate.





I've measured the span of the wing, the height of the vertical tail, the length of the tip and the length of the root for each of the two planes. I've then divided the last 3 measurements by the span of the wing. The measurements are in mm, but because I'm dividing two measurements, the units don't matter as long as they're the same. The results are in the table below. As you can see, the numbers are quite similar. This is not surprising since the planes look similar.

Plane	Span	Height	Tip	Root	Height/Span	Tip/Span	Root/Span
737	70	15	5	15	0.21	0.071	0.21
A320	72	14	4	15	0.19	0.056	0.21

Now it's time to design my tail. I want mine to be a bit squarer, with the tip a bit longer because my plane is designed to fly slower. It also won't tilt backwards as much. I've drawn my tail, as you can see below, and done the same measurements.

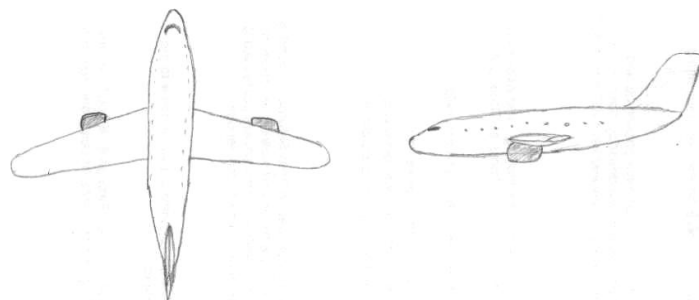

Plane	Span	Height	Tip	Root	Height/Span	Tip/Span	Root/Span
Mine	130	26	14	25	0.20	0.108	0.19

You might notice that my measurements are bigger than the other two planes, but once divided by span they are roughly the same. The last 3 numbers are the ones we need to compare. The height of my tail, divided by span, is very similar to the two examples. The tip is longer, and the root is a bit smaller, but the numbers are close. If my tip/span had been something like 0.010, it would probably be too small

and I should go back and make it bigger. The first time I drew my tail it was about half as big as it should've been, and I had to go back and try again.

This approach can also be used to check the size of other parts of the plane. For example, I could now compare the length of my fuselage, the width of my wing and any other dimension I liked. If I was trying to copy the 737 exactly, I could measure lots of measurements and then reproduce them to the size I need by picking my wingspan, then multiplying the 737 tip/span, for instance, by the new wingspan. If I was trying to make something different I would probably only use this approach for important parts like the tail and maybe the wing, and I would design the rest myself.

*Key idea:*

**Base the size of your tail on other, similar aircraft that already exist.**

## **Control Surface Sizes**

Control surfaces are the parts of the plane, usually on the wings and tails, which help control the aircraft. We've already discussed the three most common and important ones – ailerons, elevators and rudders. We didn't discuss ailerons in either of the last two learning modules so we'll discuss them here. The size of a control surface, like the size of the tail, changes a lot during design, and is usually based on complex stability and control calculations. Big control surfaces will make a plane turn, roll or climb faster, but they also cause more drag and require more force to move. This can be a problem for pilots. If the force needed to move the control surfaces is too great, the pilot will be worn out trying to fly the plane! This consideration is not as important for model planes, as the servo motors used to move control surfaces are usually stronger than the forces placed on the control surfaces by the passing air. There are a few key tips on how big your control surfaces should be, so we'll look at them now.

Ailerons are located close to the tips of the wings than the fuselage for the same reason that the tail is at the back of the plane. Ailerons are used to rotate the plane around the centre of gravity, which is in the middle of the fuselage. Placing them near the outer edge of the wing increases this distance and therefore increases the effectiveness of the ailerons. For this reason, ailerons on a plane usually start at or near the tip and go to about half way along the wing. You'll notice on the Extra 300 and ACE model planes, however, that the ailerons/elevons go all the way to the fuselage. While the extra length doesn't help to roll the plane quicker, it makes construction easier. Normal planes have another control surface called a flap that usually goes between the aileron and the fuselage, but your model plane doesn't need flaps to help it fly so we'll ignore them. On most planes the aileron covers up to a quarter of the width of the wing, but on the Extra 300 it covers half. Again, this is fine for model planes, so you can decide whether you want large ailerons or smaller ones and your plane should still fly well.

Elevators and rudders usually cover the whole length of the horizontal or vertical stabilizer. They can be anywhere from a quarter to half of the width of the stabilizer, with low speed aircraft having larger elevators and rudders than high speed aircraft. On the Extra 300, the rudder and elevators cover even more than half of the tails. Another thing you may notice is that the tips elevators and rudders cover the whole tail, while closer to the fuselage they only cover half. This extra area at the tip is called a horn. Many planes have them, and they are used to balance the weight of the elevator or rudder around its hinge, and also to make the rudders and elevators easier for the pilot to move. These factors aren't important on light model planes, so you can decide whether or not you want to include horns in your design based solely on whether you think they look cool or not.

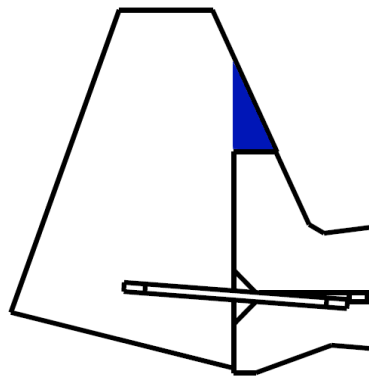

Extra 300 tail with horn highlighted in blue.

One last thing to note – elevons on delta wings should also cover the length of the wing, but they will only cover part of the width as the wing is much wider than normal. If you're designing a plane like this, use the ACE as an example for your elevon design.

*Key idea:*

**Ailerons can cover half or all of the length of your wing, and between a quarter and half of the width.**

**Elevators and rudders can cover all of the length of your tails and half the width or more.**

**Images** - Boeing 737 from below - [http://upload.wikimedia.org/wikipedia/commons/7/7a/Transaero\\_b737-400\\_planform\\_ei-cxk\\_arp.jpg](http://upload.wikimedia.org/wikipedia/commons/7/7a/Transaero_b737-400_planform_ei-cxk_arp.jpg)

- Boeing 737 from the side - <http://www.fortunecity.com/oasis/canyon/56/qantas737-400-vh-tjl.jpg>

- Airbus A320 from below - [http://upload.wikimedia.org/wikipedia/commons/f/f8/Iberia\\_a320-200\\_planform\\_ec-hyc\\_arp.jpg](http://upload.wikimedia.org/wikipedia/commons/f/f8/Iberia_a320-200_planform_ec-hyc_arp.jpg)

- Airbus A320 from the side - [http://farm3.static.flickr.com/2078/2492421697\\_290e3cce81.jpg](http://farm3.static.flickr.com/2078/2492421697_290e3cce81.jpg)

*Advanced concept:*

## Designing Canards

Canards, which we mentioned in Learning Module 3, are horizontal stabilizers placed at the front of a plane. The Wright Flyer, the first successful powered aircraft, had canards, as did a few other early designs, but the conventional tail configuration became the most used. Canards are still seen occasionally, particularly on high speed fighter jets. Canards can range from small surfaces used for control to large surfaces nearly as big as the main wing used to generate lift. We will focus on small control canards, as these are easier to design.

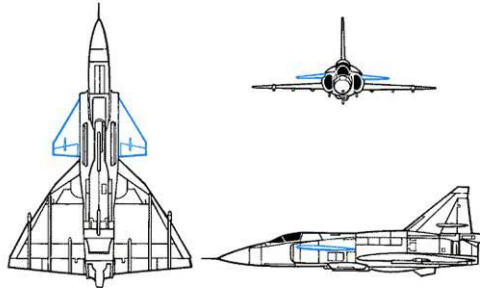

Saab Viggen Fighter Jet with canards highlighted in blue. These canards are bigger than control canards normally are.

(Image from

[http://upload.wikimedia.org/wikipedia/commons/6/60/SaabViggen\\_Canards.jpg](http://upload.wikimedia.org/wikipedia/commons/6/60/SaabViggen_Canards.jpg))

Canards are uncommon because it is hard to design a stable plane with canards. When an aircraft with canards is disturbed by a gust of wind, the canard will tend to cause the plane to continue in the direction of the disturbance. Pilots need quick reactions to return the aircraft to level flight, or it will keep flying away and might crash. High speed jets use complex computer control systems to move their canards and keep the plane flying where the pilot wants it to go.

Radio controlled planes usually don't have complex computer control systems, unless they have an autopilot, but we're not considering those that do. So, if you really want to put canards on your plane, what should you do?

Well, some of the tail design principles are the same and some are reversed. The canards should be close to the nose of the aircraft. If you're putting canards on your plane you may need to put the engine at the back, or place the battery a long way back, so that the centre of gravity will still be near the start of your wing. Your wing will also be further back along the plane, and you might have to make your vertical tail bigger because it will be close to the centre of gravity (remember that you can't put it at the front.)

The size of your canard should be chosen the same way that the size of a tail is chosen, by looking at similar planes. Obviously these planes must have canards. Looking at other planes will also give you an idea of what shape your canards should be, but you can choose this yourself if you prefer.

Small control canards on fighter jets often rotate as a single piece, rather than having a separate elevator. This is hard to do with a radio controlled plane, so I suggest you place elevators on the back end of your canards. Like normal elevators, they should cover the whole length and about half the width of the canard. You can use horns if you like the look, but they would be unusual in a canard.

I suggest that you don't try a canard design on your first plane. You might even like to put canards on that don't move and fly the plane with elevons. If you do use canards, be prepared for lots of crashes and a hard time flying in a straight line. But if you don't try it you'll never succeed so good luck!

## Learning Module 7

# How powerful should my motor be?

---

Airplane engines are often the most complex single component in the aircraft. It takes as much time and money to develop a new engine as it does to develop a new plane and almost all planes are designed to fit existing engines. Model plane engine design is somewhat simpler, as a large number of engines are available on the market to fit almost any requirement. We'll briefly look at how professional airplane designers choose an engine, and then look at how to choose the right engine, propeller and everything else for our model planes.

### Traditional Aircraft Design

The traditional aircraft design process is somewhat different to what we've outlined here in these Learning Modules. The first step in aircraft design is to determine how much a plane will weigh. This may seem unusual, but an aircraft's weight is very important, and can actually tell a lot about what a plane is designed to do. The weight is determined by working out what the plane should do – how far it needs to fly, how many passengers it needs to carry, how many turns and manoeuvres it needs to do – and comparing the plane to other planes designed to do similar things. This process tells the designers how much the plane will weigh, how much fuel it needs to carry, and how many passengers/how much cargo it can carry.

Once an estimate of the plane's weight is found, the designer will analyse a number of flight conditions to work out how big the wing should be and how big the motor should be. There are a number of rules about how quickly a plane needs to be able to climb, how high it should fly and a number of other things. These rules are set by aviation lawmakers like CASA (Civil Aviation Safety Authority) in Australia and FAA (Federal Aviation Administration) in America, and they determine how powerful airplane engines should be. Designers also look at the airports their plane should be able to take off from and work out how long the runways are. Shorter runways usually need planes with bigger wings and more powerful engines. Very short runways, like those found on aircraft carriers, use powerful catapults to launch planes and arresting wires to slow them down on landing, and planes need to be designed specially to suit these.

This process tells designers how powerful their engine needs to be. Usually, they will then select an engine that produces enough thrust to satisfy these requirements. If the available engines are not powerful enough, they may have to change a few things about their design to make it lighter. They might decrease the range, which decreases the amount of fuel the plane needs to carry. Sometimes designers have a specific engine in mind before they begin design, in which case the whole process will revolve around this engine, and other things like range, passengers and performance (maximum speed, how high it flies etc) will be adjusted to fit the engine. Whether a specific engine is chosen or not, the designer will have already decided on an engine type. This will be either a piston engine, like in a car, driving a propeller, or a jet engine. The jet engine may also drive a propeller, or it may just accelerate

air by heating it. The choice of engine will affect the planes that the designer compares their design too during the first step of determining how much the plane will weigh. Once the engine is chosen, other details like where to mount the engine, where to put fuel tanks and what controls the pilot needs will be worked out during the rest of the design process.

## **Model Planes**

The process for designing a model plane, as we've seen, can be somewhat different. Many engines are available, and so specific engine choice can be left quite late in the process. One decision that should be made early, though, is what type of engine to use. Model planes can be built using small jet engines, but these planes often cost as much as \$30,000 or more and require expertise, very careful construction and a very good pilot. For a long time, the most popular engine was a small piston engine, like the engines used in cars, lawnmowers and many other common machines. Piston engines, compared to jet engines, are simple and safe. The engines use petrol, which allows the planes to fly a long time on a small, light tank. Recently, electric motors have become popular with small aircraft fliers. Electric motors are even simpler and safer than piston engines. They are also easier to mount on a plane, as they are lighter, and they can be more responsive than piston engines. They are often cheaper than piston engines and usually much quieter. Electric motors do not provide as much flight time, as batteries are heavier than fuel compared to the amount of energy they can provide, but batteries are rechargeable. We will be focusing on electric motors here, as these are most suited to the simple foam aircraft you'll be building. First, we will choose the right propeller.

## **Propeller selection**

Propellers come in many different sizes and shapes, and selecting the right one can be difficult. The first thing to do is to decide how fast you want your plane to go. You may have decided this already when you chose what type of plane to build (see Learning Module 3). If you want to make a fast plane, like a model jet fighter or passenger jet, you will want a small propeller that spins very fast. If you want to make a slower plane, like an acrobatic stunt plane, you'll want a larger propeller that spins slowly. This might seem unusual; surely a big propeller works better and pulls faster? Well, it's not necessarily the case. Big propellers move more air every time they rotate, but this air provides resistance. This means the motor that turns it must be very strong. As it turns out, you can have a strong motor that turns slowly or a weaker motor that turns quickly, but we'll discuss this later. Make sure you select a propeller designed for electric motors. If you want the motor at the front, select a normal propeller but if you want it at the back you'll need to get a different type of propeller called a pusher.

Propeller sizes are listed in inches, and usually have two numbers. The first number will tell you the diameter of the propeller, which is how long it is from tip to tip. The second number is called the pitch. The definition of pitch is confusing, but it is an indication of how steep the propeller is. A propeller with a pitch of 0 would be completely flat, and the higher the pitch the more the blades are rotated. A high pitch propeller will pull more air through each time it turns, but it will need a stronger motor. For

example, an 8x5 propeller has a diameter of 8 inches and a pitch of 5 inches, so it will need a stronger motor than an 8x4 propeller.

If you want to make a fast plane, try a 6x4 propeller. You could experiment a bit with different diameters and pitches (bigger or smaller), but this is a good place to start. A smaller propeller might make your plane go faster, but a larger one will make it accelerate faster.

If you want to make a slow plane that can do plenty of tricks, try a 10x3.8 or 10x4.7 propeller. Once again you can experiment with this; a 9 inch diameter will go a little bit faster but may not climb quite as well.

*Key idea:*

**An XxY propeller has a diameter of X inches and a pitch of Y inches, where higher pitch needs a stronger motor.**

**Fast planes should have small propellers like 6x4s**

**Slow planes should have large propellers like 10x3.8s**

## Motor Selection

Once you've picked your propeller, you need to find a motor to turn it. As we mentioned earlier, motors are usually designed to be strong and slow turning or weak and fast turning. The power of a motor is the strength of the motor multiplied by the speed it turns, so two motors with the same power could be designed for completely different things, one turning fast and the other slow. Large propellers need strong, slow turning motors and small propellers need weaker, faster turning motors. With regard to size, you will probably use a motor that takes in about 100 Watts or more. If the motor manufacturer doesn't list the wattage, multiply the voltage required (probably 11.1 Volts, see the battery section) by the current drawn (anywhere from 9 to 14ish Amps should be ok) and this will give you your power rating in watts. The motor you should get is called a "**Brushless Outrunner.**" These motors are more efficient than brushed motors and they spin slower, so they can be attached directly to propellers without needing a gearbox.

The kV rating of a motor is used to determine whether the motor should be used for strong, slow turning or weak, fast turning. The higher the kV the faster and weaker the motor will turn. Motors will usually indicate what size propeller they are designed to work with. If you're looking at an online store, a number of details will be shown with the motor, and this should include a suggested propeller size. As a guideline, fast planes with 6x4 propellers should have a motor around 2200 kV (2000-2400 should be ok) and slow planes with 10x3.8/10x4.7 propellers should have a motor around 1000 kV (800-1200 should be ok).

The motor should also tell you what size ESC you need. An **ESC**, or **Electronic Speed Controller**, is a small electronic circuit that controls the motor. The ESC connects to the battery and the radio receiver. It takes the throttle command that you select on your radio transmitter and runs the motor at the right

speed, using power from the battery. The motor page might tell you to get a 20 or 30 Amp ESC, so find one close to this and buy it. ESCs are fairly similar, expensive ones may work a little bit better or last a bit longer, but all ESCs should work well enough to get you flying. The ESC also distributes power from the battery to the radio receiver and the servos, so it's a very handy thing to have.

*Key idea:*

**Use a brushless outrunner motor that runs on 2 or 3 cell batteries.**

**Fast planes should use a 2200 kV motor or similar.**

**Slow planes should use a 1000 kV motor or similar.**

**The motor specifications will tell you which propellers they work well with and what size ESC to buy.**

## Battery Selection

Choosing a battery is fairly straight forward, but should be done with caution. Batteries can be very dangerous if they're chosen poorly or mistreated. The first thing to select about your battery is the number of cells. We will be using **Lithium Polymer batteries**, called **Li-Po's** for short. These provide the most power for the least weight out of all the commonly available batteries. Li-Po batteries commonly have anywhere from 1 to 6 cells. You should use either a 2 or 3 cell battery, depending on what your motor requires. Note that manufacturers sometimes use different codes, so a 2 cell battery may also be called a 2S battery or a 7.4 Volt battery, and a 3 cell batter may also be called a 3S battery or an 11.1 Volt battery.

The next thing to select is the capacity of the battery. This will tell you how long your plane will fly for. Larger capacity batteries will keep a plane flying for longer, but they are also heavier, and they may slow a plane down and make it less manoeuvrable. Most simple electric planes will fly for about 10 minutes. You can choose a battery as small as about 700 mAh or as big as about 2000 mAh. It might be wise to start with a small battery and learn to fly on that, and then progress to bigger batteries if you need more flight time.

The final step is very important to make sure that your battery doesn't get overworked. Batteries have something called a C rating. This measures how much power the battery can give out at once. Think of it like a pipe with water flowing through it. A big pipe can provide lots of water quickly, while a small pipe usually provides less water in the same amount of time. The C rating is like the size of the pipe – a big C rating provides lots of power quickly. So why not just get the biggest C rating you can? Well, bigger C rating batteries are a little bit more expensive and they're heavier, so if you don't need it, don't buy it.

To work out what C rating you need, you'll need to know the capacity of your battery and the maximum current your motor will draw. To find out how much current your battery can supply, multiply the C rating by the capacity of the battery (in mAh), and divide by 1000. This will give you a maximum current, in

Amps. This current should be greater than the maximum current your motor might use, with a bit extra just in case. Let's look at an example.

I'm building a plane and the maximum current my motor might need is 12 Amps. I've chosen a 1300 mAh battery, and I need to decide between three C ratings: 5, 10 and 15. We'll start with 5 C. The maximum current this can produce is

$$\text{Current} = \frac{5C \times 1300 \text{ mAh}}{1000} = 6.5 \text{ A}$$

This is less than what I need, so I can't use this battery. Next is the 10C battery. This will give me

$$\text{Current} = \frac{10C \times 1300 \text{ mAh}}{1000} = 13 \text{ A}$$

13 Amps is more than the 12 Amps I need, but only just. If I use a 15C battery, I will get

$$\text{Current} = \frac{15C \times 1300 \text{ mAh}}{1000} = 19.5 \text{ A}$$

This is quite a bit more than I need, but I'll probably use this battery to be safe.

*Key idea:*

**Use a 2 or 3 cell battery, depending on what your motor needs.**

**Choose a capacity between 700 and 2000 mAh.**

**Make sure your C rating is high enough for your motor.**

### Where should it all go?

Now that you have a propeller, motor, esc and battery, you need to work out where to put it all! The propeller goes on the motor – you don't have a lot of choice there. You've probably designed a plane with the motor at the front, so put it there. If not, put it at the back, or on the wings, wherever you have designed it to go. The ESC should go somewhere on the fuselage. It will probably need to be near the motor so that the motor wires and ESC wires can reach. You'll need to get some kind of connector, like bullet connectors, and attach these to the wires so that you can connect the motor and ESC wires. The placement of the battery is important for stability and will be discussed in Learning Module 8.

The motor should be attached using a motor mount. Have a look at the build instructions for the ACE and Extra 300 to get an idea of how this is done. The propeller can be attached using a prop saver, a flexible attachment that prevents propellers from breaking as often during crashes, or using the nuts provided with the motor. Instructions for this should come with the motor or prop saver, or can be found online. The ESC and battery can be attached using Velcro so that they can be removed and relocated

easily. All components need to have air flowing past them during flight otherwise they may overheat and get damaged. This is easy to do on a simple foam plane, as all components are attached to the outside of the plane and will have plenty of air flowing past during flight to cool them.

### **Making sure it all works**

It's a good idea to make sure everything works before you try to fly your plane. Once everything is installed, plug it all in and turn it on. Your ESC will have instructions about calibration and turning on. This will include the order in which everything must be turned on and the position of the throttle. Once it's all turned on, keep the throttle off so the motor doesn't spin. Your plane should be secured so it doesn't fly away – getting someone to hold it will do. Make sure nothing is near the propeller, as the propeller will damage anything it runs into, and probably itself as well. Slowly increase the throttle until the propeller begins to turn, and make sure the propeller is turning the right way. You should feel the air being blown towards the tail of the aircraft. If the propeller is spinning the wrong way, turn everything off. Find the connection between the motor and the ESC and unplug two wires. Reconnect these wires in the opposite order, and the motor should spin in the opposite direction.

If everything works during this short test, secure the plane well and turn it on again. Run the throttle up to about three quarters full for 10 seconds, then return to zero and turn everything off. Check the temperature of the motor, ESC and battery. They might be warm, but they shouldn't be too hot to touch. If they're not too hot, try this again for 20 seconds, then a minute. If it passes all these tests it should be safe to go and fly. If something is too hot, you'll have to change one of your parts. A hot battery might mean you need a bigger C rating. A hot motor might mean the wrong size propeller. Check all your numbers again and make sure you haven't got anything wrong.

When you fly your plane for the first time, fly slowly and for only a few minutes. Land the plane and check again that the motor, battery and ESC are not too hot. If the plane passes this test, you've designed a good, safe power system!

### **Charging your battery**

Battery charging can be dangerous if it's done wrong, so here's a few tips on how to do it right. First, you should use a battery charger designed to charge Li-Po batteries. Some chargers also charge other batteries, so read the instructions and make sure the charger is set to Li-Po mode. Also make sure the charger can charge batteries with 2 or 3 cells (depending which you're using) and that the charger is set to the correct number of cells. You should use a balance charger when you can. Balance chargers plug into the small connector on the battery with 3 or 4 wires (3 for 2 cells and 4 for 3 cells). These chargers charge each cell of the battery individually. Other chargers may overcharge one cell and undercharge others. This will shorten the life of your battery and might be dangerous.

If something goes wrong during charging the battery could become a fire hazard. You should always charge batteries outside on concrete or other non-flammable surfaces. When a battery looks puffy, at least one cell has been damaged and it's time to get rid of the battery. Damaged cells can burst into

flames and damage your plane or seriously injure people nearby. Don't throw your batteries straight into the bin - you'll need to dispose of them properly. You might be able to dispose of them at a mobile phone shop, as mobile phone batteries are also Li-Pos. If not, ring your local hobby store and ask for help.

Your ESC should warn you when your battery is running low during flight. It will probably either turn the motor off or slow it down. When this happens, it's time to land quickly and disconnect the battery. You should never let a Li-Po battery go completely flat, or it will damage the cells and will not return to a full charge. If your Li-Po gets too flat, the cells may go puffy and you may have to get rid of it. If you crash your plane badly and the Li-Po is damaged, you should also throw it away rather than take the risk of charging it. If you charge it, it may become puffy and dangerous.

*Key idea:*

**Li-Po batteries can be dangerous.**

**Use a balance charger designed for 2/3 cell Li-Pos.**

**If a battery looks puffy, dispose of it safely.**

## Learning Module 8

# Where should I put everything?

---

By now you've designed your plane, which means the position of the wings, the motor and the tail are all set. But you've still got a battery, a receiver and a few other gizmos to place. Does it matter where you put them? Well, sometimes it does, especially for heavy items like the battery. It turns out where you put things has a big effect on how easy it is to fly your plane. There are a lot of complex methods for working out how easy your plane will be to control, but there's also a few simple rules that will make your life a lot easier, so we'll take a look at them

### Stability

When you fly a plane, there are certain ways you expect the plane to behave that make it easier to fly. One of the most important behaviours of the plane is stability. To help understand this, think about a marble sitting in a ditch, as shown on the left below.

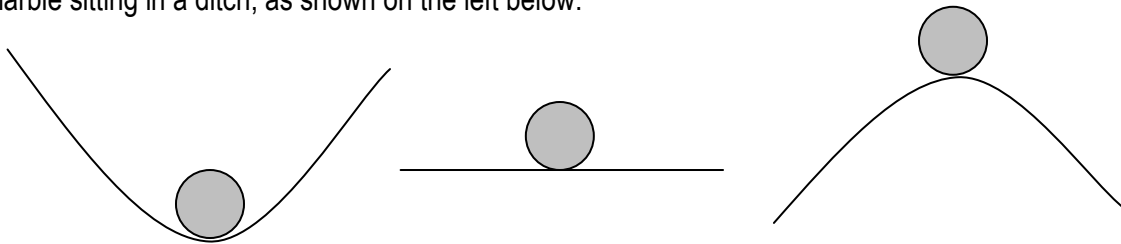

The marble is currently sitting still. If you moved the marble to the left or right, it would move back to where it was. This is called **positive stability**, and it's a good thing. The marble on the right is sitting on top of a hill. It's currently sitting still, but if you moved it a little bit it would roll down the hill, and wouldn't return to where it was. This is called **negative stability**, and it's usually a bad thing. The marble in the middle is sitting on a flat surface, and it's also currently sitting still. If you moved it to one side, it would sit still in a new spot, and it wouldn't return to its old spot or move to another one. This is called **neutral stability**, and it's usually better than negative stability but not as good as positive stability.

But how does this relate to your plane? Well, imagine you're trying to fly in a straight line (it's harder than it sounds!) and the wind changes a little bit. It'll probably make your plane change direction. If your plane is positively stable, it will start turning back towards the direction you were going. That'll make flying in that direction a lot easier. If it's neutrally stable, it'll keep going in this new direction and you'll have to turn the plane back yourself. If the plane is negatively stable, then it'll continue changing direction, which can be disastrous. Imagine you were flying fairly low in the sky, and the wind made your plane turn down towards the ground. A negatively stable plane will keep turning down, and probably crash before you can stop it!

*Key idea:*

**Positively stable planes are much easier to fly because they continue flying in one direction.**

**Negatively stable planes are hard to control.**

### **Too much of a good thing**

As you saw from the previous example, a positively stable plane is a good thing. However, you can have too much stability in your plane. If your plane is very stable, it will produce very strong forces to keep it flying the way that it is. But when you want to change direction, to climb or turn around for example, it will take a lot of effort to overcome these forces. Because of that, the plane will be very slow to turn, and it will be hard to fly.

How stable should your plane be? It depends what you want your plane to do! If you're learning to fly, you want a stable, slow plane to practice on. But as you get better at flying, you can make your plane less stable so that it turns quicker and can do more tricks. Some types of plane, like acrobatic planes and jet fighters, need to be very quick at turning, so they are designed to be less stable (see Learning Module 3). Sometimes, modern fighters are even designed with negative stability to turn very quickly. While a human pilot could not safely fly an aircraft like this, computer control systems are a lot quicker than human pilots. They can detect when the aircraft is heading the wrong direction and turn it back in a split second. Using these control systems, humans can now safely fly aircraft that would've been impossible to fly 50 years ago.

So how do you change how stable your aircraft is? There are many factors that affect the stability of an aircraft, but one simple factor that you can control is the weight balance of the aircraft. To understand that, we'll need to look at something called the centre of gravity.

### **Centre of Gravity**

When you try to balance a ruler on your finger, you put your finger near the middle so that the weight of the ruler to the left of your finger equals the weight on the right. (Go on, try it now!) The **centre of gravity** is the point where you can put your finger to make the ruler balance. Now, if you put something heavy, like an eraser, on one end, the ruler will no longer balance near the middle. You'll have to move your finger closer to the end with the eraser. The centre of gravity has now moved towards the heavy object.

This is the same approach we use to change the centre of gravity on your plane. Think of your plane as a ruler, and your battery as an eraser. (We're using the battery because it's the heaviest part, so it'll have the biggest effect on the centre of gravity) If you pick up your plane by pinching somewhere along the top, you'll probably notice that one end drops down. Move your fingers closer to the low end and it will droop less. Continue this until your plane doesn't droop too much either way, and you'll have a

rough idea of where your centre of gravity is. Now, if the middle of your battery is in front of this, the centre of gravity will move forwards, and if it's behind it'll move backwards.

So now you know what your centre of gravity is and how to change it. But how does this affect the stability of your plane? The *how* is quite simple, but the *why* is a little more complicated. We'll talk about the *how* now, and we'll have a brief look at the *why* in the advanced concept later on.

## A stable plane

You've probably noticed that paper planes fly better when you put something heavy, like a paper clip, on their nose. This moves the centre of gravity forwards, making the plane more stable. To make a plane stable, the centre of gravity should be near the nose of the aircraft. If your plane has a normal configuration, it should be near the front of the wing, or even further forward. The closer the centre of gravity is to the nose, the more stable your aircraft will be. This isn't the only thing that affects stability, but it's one of the most important and one of the easiest to control. It can also be changed once you've built your plane. If you mount your battery using Velcro and have a long strip on the plane, you can move the battery backwards and forwards to adjust the centre of gravity.

So, where is the right spot? Well, you could do a bunch of maths to help you make an educated guess, but it's easier to work it out with a few flight tests. It's a whole lot more fun too! First, put the battery quite close to the nose, and check that your centre of gravity is quite far forward. Then, take it for a flight! You should find that it's very stable, but it might be too stable. If it takes too much effort to fly or you think you'd rather have it turn faster, move the battery back a little and fly it again. If it turns too quickly and you keep crashing, you'll need to move the battery forward again. Using this simple procedure you can find a configuration that works well for you. Most people find that having the CG about a quarter of the wing width behind the front edge of the wing is a good place to start.

*Key idea:*

**The further forward the centre of gravity is the more stable the plane will be.**

Now, we've only discussed something called longitudinal stability. There are other types of stability, but these aren't usually a problem for radio controlled planes. However, another important design principle is to keep your plane as close to symmetrical along the centre as possible. This means the left half and the right half have the same size wing and tails in the same position, and the motor is in the middle. It also means you should put other things like your battery and receivers as near to the middle as possible. You probably won't be able to get it perfect, but near enough should be good enough.

*Advanced concept:*

## Why should the centre of gravity be so far forward?

To understand why the centre of gravity affects the aircraft stability like it does, we need to look at another, slightly more complicated point on the aircraft.

### The Aerodynamic Centre

The lift generated on a wing is related to the pressure applied to the wing by the passing air. This pressure is different in different places on the wing, and some places produce more lift than others. Usually, the front of the wing produces more lift than the back.

To help account for this, we define a point called the **aerodynamic centre** which represents where the lift forces seem to be acting. For most wings this is usually one quarter of the way through the wing, starting from the front of the wing. Now, the tail also generates some lift, usually downwards, which moves the aerodynamic centre further backwards. It also moves if the wings are swept backwards instead of straight. But for our purposes, putting it at a quarter of the wing is good enough

### Stability

So, now we have two points, the centre of gravity and the aerodynamic centre. At the centre of gravity we have a downwards force (weight), and at the aerodynamic centre we have an upwards force (lift).

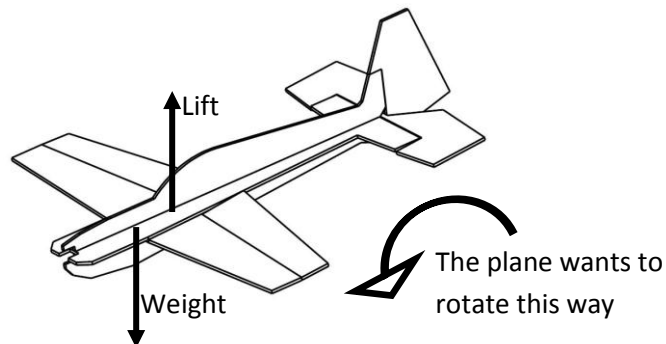

Now, you can see from this diagram that the plane is being twisted by these two forces to push the nose downwards. (If you don't understand this, put your pen on your desk and push left on one end and right on the other and watch it spin.) There are other forces that balance this turning in normal flight. But consider what happens when a sudden gust of wind rotates the plane and lifts the nose. The wings are now at a steeper angle to the incoming air, which increases their lift (See Learning Module 5). If the lift force is bigger, then the force turning the plane's nose down will get bigger. This will return the plane to its original heading.

Further explanations require a better understanding of the other forces on the plane, but this simple example will hopefully give you a basic understanding of aircraft stability.

## Further Reading

### **Beginner's Guide to Aeronautics**

<http://www.grc.nasa.gov/WWW/K-12/airplane/index.html>

This website was made by NASA to educate American primary and secondary school students. It covers everything you could want to know about how planes fly, from a basic introductory level through to early university level studies. This site doesn't have much specifically applied to aircraft design, but many aircraft design resources will assume you know more than you probably will. If you find a concept you don't understand, this is a great place to find an explanation.

### **Perfect Park Flyer Power Systems**

<http://www.rcpowers.com/e-books.htm>

This is an e-book written by someone who knows a lot about model planes, especially simple ones made from foam. The book covers everything you need to know about power systems and was one of the main inspirations for Learning Module 7. The forums on the site are also worth visiting. The Extra 300 plans come from here and there's a build guide online to help you out, as well as lots of advice from people who've tried new things and failed.

### **Simplified Aircraft Design for Homebuilders**

Book by Daniel Raymer

This book is written for people who want to build their own plane. It's intended for building full size, flyable planes, but it makes an interesting read. Things are presented as simply as possible. A copy of this book can be found at the University of Adelaide Library.

### **Aircraft Design: A Conceptual Approach**

Textbook by Daniel Raymer

This is the older brother of the last book – one of the standard textbooks on Aircraft Design taught around the world. The book is well written but it's aimed at more advanced users, so it will be a hard read for high schoolers. This textbook is available at the University of Adelaide Library, and is recommended for advanced year 11 or 12 students doing extended projects in aircraft design.

## Project Suggestions

Students looking to research specific aspects of aircraft design or performance might like to consider one of these areas. Finding a mentor to help out will be essential – a good place to look would be university students, recent graduates or old radio controlled aircraft veterans.

### General Airfoils

There's a lot that can be learnt about airfoils. The planes in this book usually use flat wing sections, which are far from efficient. Students can look at how airfoils work and what different airfoils are designed to do. Depending on resources, they could test different airfoil designs. Wings with airfoil sections are harder to manufacture, but this may be within the scope of the project. A mentor will help a lot with this, especially one with knowledge of the NACA airfoil classifications.

Specific resources – Javafoil (<http://www.mh-aerotools.de/airfoils/javafoil.htm>)

This tool generates different airfoil shapes. These can be printed onto paper and used as templates for construction. The tool also estimates lift, drag and pitching moment coefficients, which can be used to compare airfoils.

### KF Airfoils

KF airfoils, or Kline Fogleman airfoils, are a special type of airfoil first designed by experiments with paper planes. KF airfoils are popular with radio controlled plane enthusiasts as they can be made from layered sheets of foam. For example, a second sheet of foam is placed over the wing, covering the front half of the wing. The front of this wing is then rounded using a hot wire. KF airfoils are much more efficient than flat wings, and have a number of interesting properties. They could be studied alongside other airfoils or on their own.

Specific resources – Search “KF Airfoils” on Google/Wikipedia

The current Wikipedia article gives a good introduction to the topic. It contains a picture of 8 different types, with a list of their specifics and benefits. This picture was made by Richard Kline, one of the inventors of the KF airfoil. Many RC forums have lots of information about KF airfoils.

## **Motor testing**

By buying a few different motors/propellers, students can test different combinations to see which provide more thrust, which use more power and which are the most efficient. Students can make a test stand that holds their motor but is free to move in one direction. Using a spring-based force gauge, they run the motor and see what force it produces. They can also use multimeters to find currents and voltages, and draw conclusions about which motor/propeller combinations work best.

Specific resources – Valley View Secondary School

Projects like this have been done at Valley View, and details can be provided. Contact Bob Haskard at [Bob.Haskard@valleyview.sa.edu.au](mailto:Bob.Haskard@valleyview.sa.edu.au).

## **Airplane structures**

The airplanes referred to in this guide are made from sheets of foam. These are structurally simple and strong enough for the job, but real aircraft structures (as well as larger models) are more complex. Students could research, for example, the structure of an aircraft wing. They could learn about spars, ribs, stringers and skinning. They could design their own wing out of balsa wood and test it to destruction by placing weights along the wing. The aim could be to determine the strongest wing with the lightest weight.

Specific resources – Wikipedia or NASA Beginner's guide

Find a good overview of a wing structure. Find definitions for spar, rib, stringer and monocoque. Look at drawings of plane wings and identify each component and the type of load it's meant to take. Then find some plans for a model plane wing built like this and experiment.

## About the Author

This teaching series was written by me, Jonathan Dansie. I've just completed a double degree in Aerospace Engineering and Computer Science, graduating with First Class Honours, and will be working with DSTO (Defence Science and Technology Organisation) in Melbourne researching aircraft flight mechanics. I graduated from the University of Adelaide.

During my final year, I wrote these lessons to accompany the construction guides put together by Joel Phillips, a Design and Technology education student at the University of South Australia. Through this I first encountered foam RC airplanes, and have been a fan ever since. I've also worked as a high school tutor throughout my university education, and have a passion for educating high school students, particularly in Mathematics, Physics and Chemistry.

I wish you all the best following these guides, and would love to hear feedback on how useful (or otherwise!) they have been and what could be improved. Thanks for reading!

Jonathan Dansie

[jon.dansie@gmail.com](mailto:jon.dansie@gmail.com)